

*Submitted to IEEE Communications Magazine*  
Special Issue on *Wideband Wireless Access Technologies to Broadband Internet*

## **Antenna Systems for Broadband Wireless Access**

Ross D Murch<sup>#</sup> and K. B. Letaief

*Center for Wireless Information Technology*  
*Department of Electrical and Electronic Engineering*  
*Hong Kong University of Science and Technology*  
*Clear Water Bay, Kowloon, Hong Kong*  
[ermurch@ee.ust.hk](mailto:ermurch@ee.ust.hk) and [ekhaled@ee.ust.hk](mailto:ekhaled@ee.ust.hk)

### ***Abstract***

*Broadband wireless access along with evolving mobile Internet and multimedia services are driving the recent surge of research and development activities for future wireless communication systems. In this paper, we provide an overview of antenna systems for broadband wireless communications and introduce some of the important issues surrounding them. The approach we use is to first provide a general framework of how antenna systems may be utilized in wireless communication systems and then describe the antenna systems themselves. In particular, we consider antenna systems for the base station, mobile station and then finally multiple input and multiple output antenna systems where antenna systems are utilized at both the base and mobile stations.*

---

<sup>#</sup> Corresponding Author. Tel: +852 2358 7044. Fax: +852 2358 1485.

In recent years, there has been a substantial increase in the development of broadband wireless access technologies for evolving wireless, mobile Internet services and next-generation cellular systems. These technologies must be able to cope with the challenging wireless environment and antenna systems in the form of adaptive arrays or smart antennas can provide an effective and promising solution while achieving reliable and robust high speed and high data rate transmission. Such systems have been proposed for wireless communications for many years [1-2]. Recently, however, research and development in this area has significantly increased [3-4] and many commercial products are now readily available for wireless communication systems. In addition, recently proposed multiple input multiple output (MIMO) antenna systems [4] or space division multiplexing (SDM) systems are further revolutionizing antenna systems for wireless communications.

The reason for the renaissance of antenna systems is that they have become one of the key technologies for increasing capacity and data rates of wireless communication systems. Their use helps mitigate three major impairments caused by the wireless channel; namely, fading, delay spread and co-channel interference. The earliest form of antenna systems for improving the performance of wireless communication systems was in the form of antenna diversity and it helps mitigate the effects of fading. Antenna diversity has been in commercial use at the base station of most wireless communications for many years. Over the last two decades, smart antenna systems (or adaptive antennas), which attempt to actively mitigate co-channel interference, have also been developed [1-2] and commercial systems are now appearing at the base station. Recently, there have also been some important developments and these include the idea of space-time receivers, space-time coding, and SDM antenna systems. The proposed wireless metropolitan area network

(Wireless MAN) standard IEEE 802.16, which is aimed at wireless broadband access is also considering the use of antenna systems for performance improvement.

In this paper, we attempt to provide an overview of all of these antenna systems for wireless broadband communications and introduce some of the important issues surrounding them. Our basic definition of an antenna system is any adaptive configuration of multiple antennas that improves the performance of the wireless communication system. The key points are that the system must be adaptive and consist of multiple antennas. Our definition includes diversity, smart or adaptive antenna systems, and MIMO or SDM antenna systems. It is also important to note that the particular form of the antenna system depends on the exact wireless system configuration, whether it is used for reception or transmission, and if it is at the base station or mobile station.

The organization of this paper is as follows. In Section 1, we introduce a framework and some general concepts that form the basis for most antenna systems. In Section 2, we discuss antenna systems in which there are multiple antennas at the base station and only a single antenna at the mobile station. In Section 3, we discuss smart antenna systems at the mobile station while in Section 4 we introduce recently developed techniques based on smart antennas at both the base and mobile stations also known as MIMO or SDM antenna systems. Finally, in Section 5 we summarize the paper.

## **1. Framework**

Wireless communication systems usually perform duplex communication between two points and here we define these two points as the base station (BS) and the mobile station (MS). In a duplex wireless communication system, it is important to understand that there can be up to four antenna systems operating. There can be

two systems in the downlink; namely, an antenna system for transmission at BS and another antenna system for reception at MS. Additionally, there can be two systems for the uplink, namely transmission at MS and reception at BS. An example of such a system is illustrated in Figure 1 where the 4 antenna systems can be readily seen. It should be noted that at the MS in Figure 1, the antennas for transmission and reception are shared, thus, providing some simplification. In general, there are  $M$  antennas at the BS for transmission,  $N$  antennas for reception at MS,  $K$  antennas for transmission at the MS and  $L$  antennas for reception at the BS. Since the antennas at the MS are shared the number of antennas needed at the MS is the maximum of either  $N$  or  $K$ . At the BS and MS, the transmission and reception processing are performed separately as indicated by the separate blocks in Figure 1.

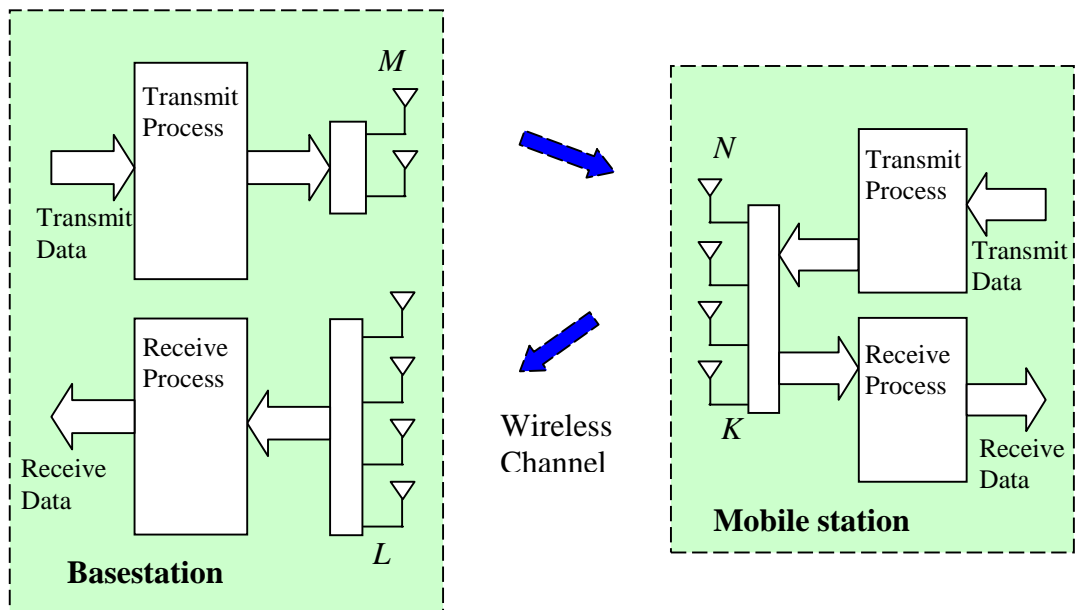
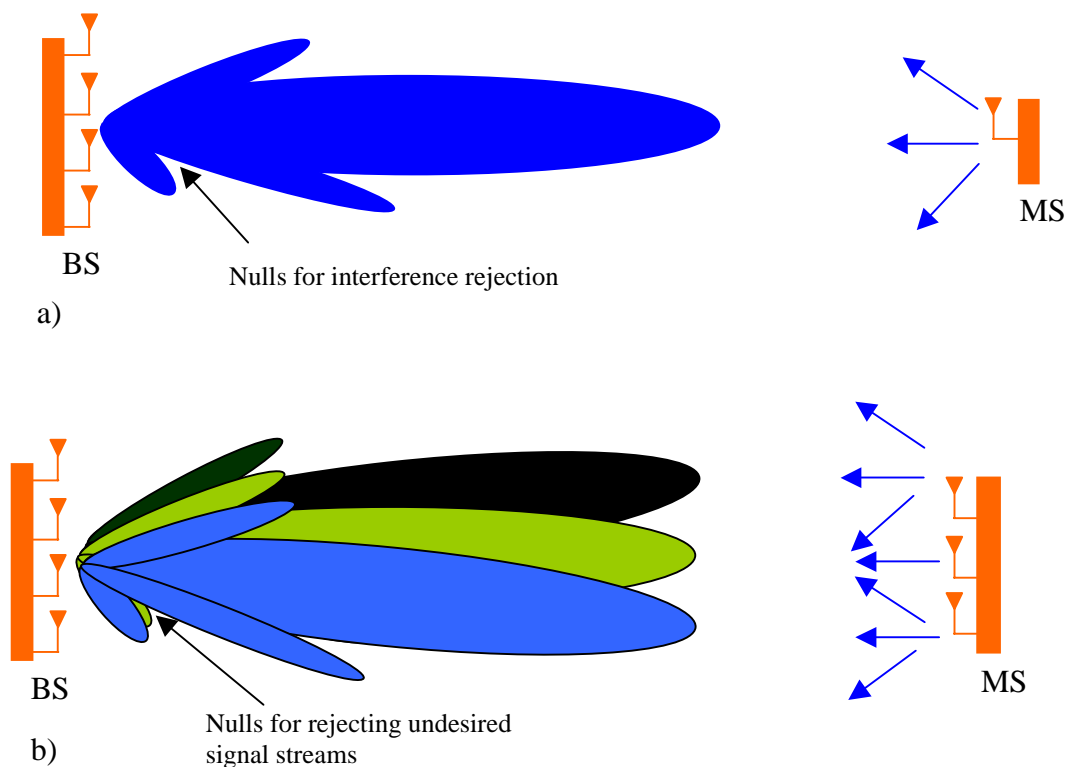

**Figure 1:** General Antenna System for Wireless Broadband Communications

In a conventional GSM system, for instance, diversity combining using 2 antennas is performed on the uplink only and therefore using our terminology it is characterized with  $M=1$ ,  $L=2$  and  $N=K=1$ . Typically, when  $M$  and  $N$  are both greater

than 1 we refer to the system as a MIMO system in the downlink (or when  $K$  and  $L$  are both greater than 1 as a MIMO system in the uplink) and this has been popularized by the V-BLAST architecture [4].

An intuitive picture of the operation of the antenna systems can be obtained with reference to Figure 2 where the antenna patterns for 2 configurations are illustrated. In Figure 2a, we illustrate an uplink system where  $K=1$  and  $L>1$  and observe that the MS radiates omni-directionally while the BS is able to shape its antenna pattern and focus it onto the MS while also rejecting interference through pattern nulls. This process is often referred to as spatial filtering since signals arriving in different spatial directions are treated differently. It should be noted that such a picture of the smart antenna is highly simplified.



**Figure 2:** Uplink Antenna Systems a) BS Antenna system with  $K=1$  and  $L>1$ . b) MIMO antenna system with  $K>1$  and  $L>1$ .

In practice, it is likely that the desired and interfering signals will arrive from many different directions and therefore the actual beam pattern on the right-hand-side of Figure 2a may appear completely different and will not reflect a focusing process. In Figure 2b, we also illustrate a MIMO system where both  $K > 1$  and  $L > 1$  and several data streams are sent simultaneously over the wireless channel. In this example, each antenna at the MS transmits a different data stream and radiates them omnidirectionally. At the BS, the antenna is able to form several beams that can select each of the data streams and correctly receive them. In this example, it is clear that the capacity of the system has been increased by a factor of three compared to a conventional system and this is one reason why MIMO systems are generating so much excitement [4].

A key research area for these antenna systems is the development of the transmit and receive processing blocks (see Figure 1). Typically, these processing blocks consist of weights that are multiplied with the incoming signals and then the resulting signals are combined in various ways and then output. This is often referred to as space processing and the blocks can be either linear or non-linear. The processing may also be done in time to help further mitigate inter-symbol interference (ISI) and then the processing can be thought of as space-time processing. An example of a linear space-time processing receiver system is illustrated in Figure 3. In this example, there are 2 antennas and 2 time taps per antenna, with  $T$  denoting the symbol period, so that a total of 6 combining weights are needed. In a CDMA system, the delay taps could be replaced by fingers of a RAKE receiver. The weights can be determined by the use of the Minimum Mean Squared Error (MMSE) criteria, for instance, when training sequences are available. Several enhancements to the general structure in Figure 3 are possible and the most common of these is the use of a

decision feedback in both time and space. A thorough investigation into the performance of various space-time configurations is provided in [5].

Another aspect that needs to be considered is the kind of channel state information (CSI) that is available. It is generally assumed that CSI is available at the receiver of most antenna systems. However, CSI is not automatically available at the transmitter and depending on the particular technique CSI will or will not be needed. Therefore, the transmitter processing blocks in Figure 1 will have to rely on either no CSI or at best some approximation of it. As a result, we can expect some performance reduction at the transmitter side of the antenna processing blocks.

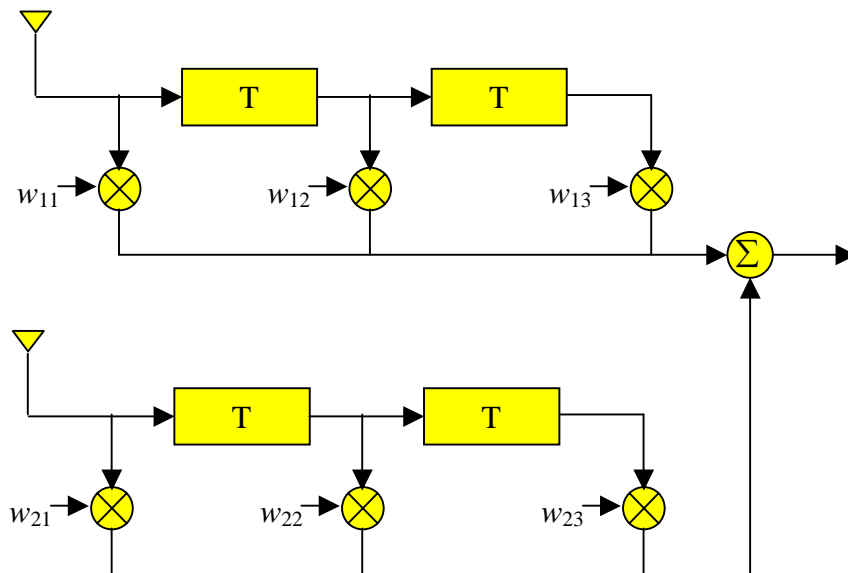

**Figure 3:** An example of a space-time receiver with 2 antennas and 2 time taps.

The type of wireless system used is also important. For example, CDMA systems typically have time diversity already incorporated through the use of the RAKE receiver and the antenna system is mainly needed for controlling CCI or MAI. However, in a TDMA system, the antenna system ideally should provide both diversity and mitigate CCI.

In the remainder of this paper, we discuss the various antenna system configurations. Specifically, in Section 2 we look at BS antenna systems where  $M > 1$  for downlink systems and  $L > 1$  for uplink systems while both  $N = K = 1$  (i.e., with a single antenna used at the MS.) In Section 3, we briefly consider MS antenna systems in which  $M = L = 1$  and  $N > 1$  for downlink operation and  $K > 1$  for uplink operation. In Section 4, we consider MIMO systems where  $M$  and  $N$  are greater than 1 for downlink systems and  $K$  and  $L$  are greater than 1 for uplink systems. Finally, in Section 5 we briefly summarize our paper.

## **2. BS Antenna Systems**

In BS antenna systems, antenna processing is performed only at the BS in either or both the up and downlinks. Uplink BS systems have been well studied and were the first multiple antenna systems to be considered for wireless communications. Less work has been performed on the downlink. However, for the wireless system to have balanced performance in the down and up links it is very important that the downlink also be considered.

### **2.1 Uplink**

#### **2.1.1 Diversity Systems**

Antenna Diversity has been known for many years and has been included in the mobile telephone BS for some time. Its primary goal is to reduce fading caused by the wireless channel. It makes use of the principle that the signals received from two or more antennas that are uncorrelated will have independent fading. Therefore, if one antenna is experiencing a faded signal it is likely that the other antenna will not, so at least one good signal can be received. Typical methods for producing uncorrelated

antenna signals are space, polarization or pattern diversity. Space diversity in the past has been most common and at an outdoor BS antenna separations of around 10 wavelengths are required. Polarization diversity is, however, becoming more popular as both antennas can be housed at the same location without spatial separation.

Three common processing techniques are used for diversity and these are known as switch diversity, equal gain, and maximum ratio combining. In switch diversity, the idea is to select the antenna with the best signal (usually the signal strength is taken as a measure of signal quality but other measures can be used such as BER or signal quality). Equal gain combining seeks to improve on this by co-phasing the signals and adding them together. Maximum ratio combining (MRC) is the optimum method in the presence of noise and weighting (and co-phasing) the signals before combining by their SNRs. The bit error probability for a BPSK MRC system with  $L$  receive antennas is given by [11]

$$P_e = \left[ \frac{1}{2}(1-\mu) \right]^L \sum_{i=0}^{L-1} \binom{L-1+i}{i} \left[ \frac{1}{2}(1+\mu) \right]^i \cong \left( \frac{L}{4\gamma_b} \right)^L \binom{2L-1}{L} \quad (1)$$

where  $\mu = \sqrt{\gamma/(1+\gamma)}$ ,  $\gamma$  is the average SNR per channel branch and where the asymptotic approximation, on the right hand side, is valid for  $\gamma \gg 1$ . It is also important to note that in antenna systems the specification of SNR can be performed in several ways. In this example, it is also possible to express it as the average receive SNR,  $\gamma_b = L\gamma$ , and is also sometimes referred to as average SNR per bit. The performance of MRC is plotted in Figure 2 in terms of BER performance verses SNR per channel branch. Comparing the no diversity configuration with MRC, for instance, we can deduce that 2 antenna diversity provides nearly 10dB advantage for BER's of the order of 0.01. Improvement is even greater with 3 or more antennas but the marginal gains become less.

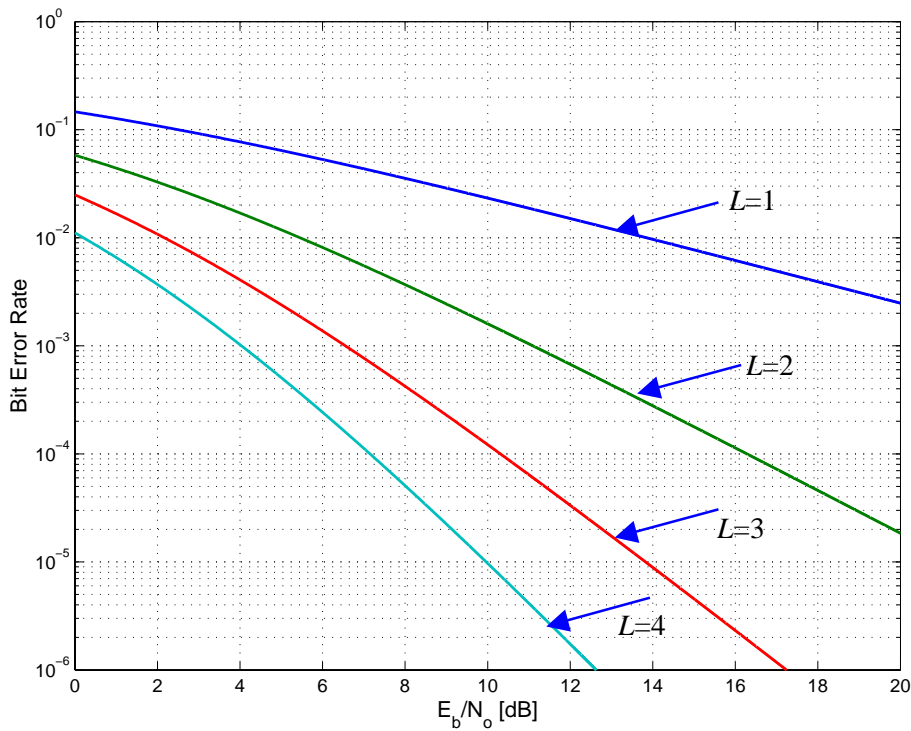
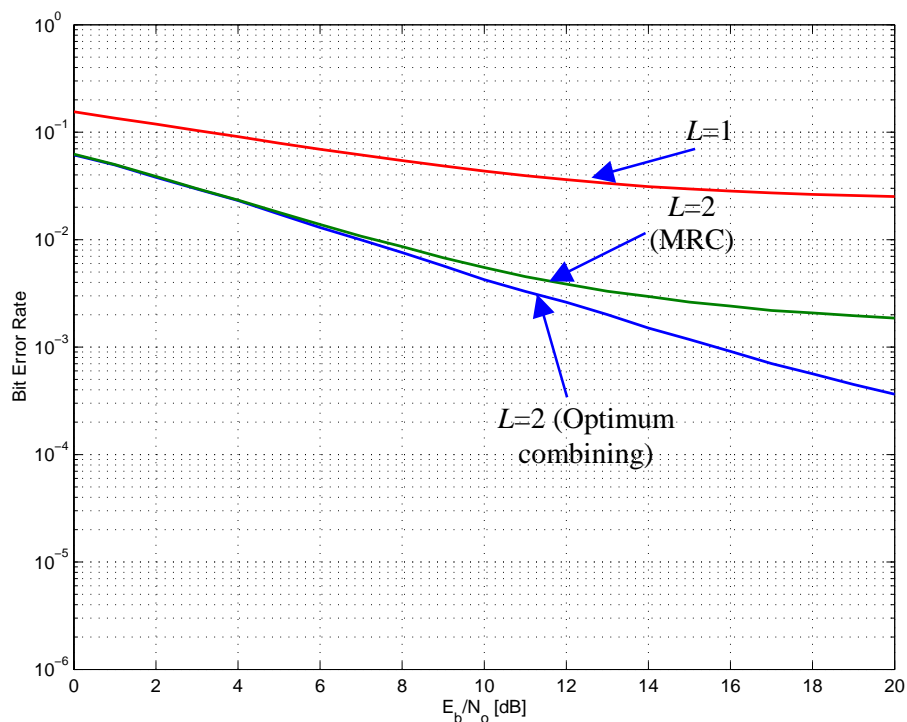

**Figure 4:** BER results for maximum ratio combining when the number of receive antennas,  $L$ , varies from 1-4 in terms of the average SNR per channel branch.

### 2.1.2 Adaptive or Smart Antenna Systems

When strong interference is also present, diversity processing alone cannot improve the signal. To cope with interference, smart antennas or adaptive array processing can be utilized to shape the antenna radiation pattern in such a way as to enhance the desired signals and null the effect of the interfering signals [1-2]. In Figure 2a, a stylized version of this is shown where it can be observed that the main beam is focused onto the desired signals and the nulls of the pattern are placed in areas where interference occurs (it should again be noted that in the wireless environment the radiating rays of the desired and interfering signals can come from many directions and therefore the illustration in Figure 2a is simplified). The adaptive or smart antenna processing is generally known as optimum combining and is based on the assumption that we already know part of the desired signal through the use of a

training sequence. This known signal is then compared with what is received and the weights in Figure 3 are then adjusted to minimize the MMSE between the known and received signals. When no interference is present optimum combining reduces to MRC. Some results are provided in Figure 5 for BPSK where there is one interferer with an SIR of 10dB. Comparing this to Figure 4, we can observe that at SNR's greater than around 10dB the BER curves without optimum combining flatten out. This is because the interferer dominates the noise and is the main cause of errors. However, when optimum combining is incorporated the BER curve does not flatten out. Comparing the optimum combining result with Figure 4 we may also note that performance is not as good as that of the case of no interference. This is because one degree of freedom is used to cancel the interference and therefore the diversity gain is not as large.



**Figure 5:** An example of optimum combining when one interferer with an SIR of 10dB is present

Practical implementation of the optimum combining approach for TDMA systems has been performed based on the training sequence within a timeslot. In general, a Direct Matrix Inversion (DMI) approach is thought useful where each packet is handled separately. Improvements to the algorithm are possible and other approaches such as LMS and RLS are also possible.

For CDMA systems, the RAKE receiver already provides time diversity and therefore the smart antenna will provide most of the gain in the area of CCI and MAI reduction. For this reason, it is generally suggested that multibeam antennas should be considered for CDMA systems [3]. Multibeam antennas use fixed beams and have less complexity with regard to weight calculation and tracking. In addition, the TDMA environment is characterized by a few dominant interferers, but in CDMA there are typically many interferers and there are not enough degrees-of-freedom in the array to cancel them all. This again supports the use of multibeam antennas for CDMA systems.

A fundamentally different approach has also been proposed based on direction of arrival techniques. In this technique, algorithms based on MUSIC or ESPRIT are used to determine the directions of arrival. Once these are known, they can be combined to find the best signal. One problem often mentioned is that the algorithms may not perform well under realistic conditions and that in real environments there are too many DOA to properly detect [3].

## **2.2 Downlink**

In principle, the methods used in the uplink can be carried over to the downlink. That is, the signal directions in Figure 2a and b can simply be reversed. However, the main problem is that there is only limited CSI available since the transmitter cannot

acquire knowledge about the downlink channel. Therefore, the transmitter cannot form the desired antenna pattern and achieve the same performance as the uplink. To overcome this problem there are typically two approaches. The first is to devise methods that do not require any CSI, but the problem is that performance gain is somewhat limited. The other approach is to attempt to obtain CSI of the downlink from the uplink receiver. In a TDD system, this is possible since the channels are in principle reciprocal (if we ignore interference) and therefore the uplink CSI should be closely related to the downlink CSI. Typically, however, there is a time difference between the down and uplink estimations and therefore the channel may have altered in this time period. In an FDD system, the up and downlink channels are uncorrelated and therefore the uplink channel cannot be used as an estimate for the downlink. However, there are some frequency invariant properties of the channels such as direction of arrivals and these can be used to provide limited information about CSI.

### **2.2.1 Diversity**

Diversity can be applied at the transmitter using the methods suggested in Section 2.1 if CSI is available. However, this is not usually the situation and one interesting diversity idea that can be used without CSI is known as space-time coding. Space-time coding is an effective coding technique that uses transmit diversity to combat the detrimental effects in wireless fading channels by combining signal processing at the receiver with coding techniques appropriate to multiple transmit antennas. A simplified version of space-time coding can be applied to the downlink in which  $M=2$  and  $N=1$ . This type of space-time coding, which was discovered by Alamouti [6], achieves the same diversity advantage as MRC with two receiving antennas and one transmit antenna. In this scheme, two signals, which are denoted by  $s_1$  and  $s_2$ , are

simultaneously transmitted from the two BS antennas (antenna 1 and 2, respectively) at a given symbol period. During the next symbol period signal  $s_2^*$  is transmitted from antenna 1, and signal  $s_1^*$  is transmitted from antenna 2 where  $*$  denotes the complex conjugate operation. The received signals are then properly combined and then detected by a Maximum Likelihood detector. This approach is very attractive as it has a very simple decoding process while achieving second order diversity without bandwidth expansion. However, a 3dB power disadvantage occurs because the total transmit power is fixed and therefore each antenna must transmit 3dB less power. Various comparisons between space-time coding and transmitter diversity, for instance, can be found in [7].

### **2.2.3 Smart Antennas**

If the downlink channel is perfectly known at the BS, then transmit processing can be obtained in a similar way to uplink combining as described in Section 2.1.2 [8]. However, when only limited information is available, then some alternative techniques must be applied to estimate the required parameters and one approach is given in [9]. Another approach that is often suggested if the directions of arrival can be obtained is to use a multibeam antenna, which selects the beam that best fits the uplink directions of arrivals and this is based on the assumption that the downlink directions of departure are similar to the uplink directions of arrival.

## **3. Mobile Station Antenna Systems**

The methods used for BS antenna systems in Section 2 can be directly applied to the MS. The main constraint, however, is that the MS needs to remain compact, comparatively low cost and its battery life not to be compromised. With these

constraints implementing antenna systems at the MS is significantly more difficult because only low complexity algorithms can be used with only a limited number of antennas. One of the major hurdles is the problem of needing additional receiver chains and this alone will greatly impact cost and battery life. Correspondingly, only few results are available for MS antenna systems and here we provide a brief summary of these. As far as the authors know, the only commercial system that employs MS diversity is the Japanese PDC system. Another area that has been actively investigated is the realizability of compact antennas for the MS and whether a sufficiently low correlation coefficient (envelope correlations of less than 0.5 are considered acceptable) can be obtained. Recent results reveal that a dual antennas can be made compact and also provide correlations of less than 0.1 [10].

### **3.1 Downlink Diversity and Smart Antenna Systems**

In the downlink of the MS, the receiver has CSI available and therefore diversity and optimum combining can be implemented if suitable low complexity algorithms can be found. A number of results have been obtained for TDMA based systems with  $N=2$  in which the trick has been to measure the channel of one of the antennas at one timeslot and then the other antenna with the next timeslot and then finally combine the antenna signals appropriately in the third and desired timeslot [11]. The advantage of this is that only one receiver chain is needed and therefore should not impact significantly on battery life. To reduce complexity even further the possible weights available are restricted to a small set and the algorithm has to simply select the most appropriate of these. Results have been achieved for both diversity and optimum combining and good performance is achieved. Obviously in the presence of strong Doppler, the channel estimates from the earlier timeslots become inaccurate and

performance degrades. Limited results have also been obtained for CDMA based systems.

## **4 MIMO Antenna Systems**

In MIMO antenna systems, there are multiple antennas at both the BS and MS. For a downlink MIMO system,  $M > 1$  and  $N > 1$  while in an uplink MIMO system  $K > 1$  and  $L > 1$ . MIMO antenna systems promise improved performance and bandwidth efficiency compared to the antenna systems we have considered in Sections 2 and 3 [4]. The key reason for this is that multiple data streams or signals are transmitted over the channel simultaneously. It is therefore possible to double, triple or quadruple (or even more) the capacity of a system and therefore achieve some significant gains over the methods in Sections 2 and 3. Several techniques for achieving these advantages have been investigated, including MLD (Maximum likelihood detection) [12], V-BLAST (Vertical Bell Laboratories Layered Space-Time) [13], and Singular Value Decomposition based (SVD) [14,15] or space-time coding [16].

In general, the above MIMO techniques can be divided into those performing processing only at the receiver (such as V-BLAST and MLD) and those performing MIMO signal processing at both the receiver and transmitter (such as SVD based techniques). A third approach is also possible in which MIMO signal processing is only employed at the transmitter [17]. The major advantage of this approach is that no MIMO signal processing is required at the receiver (although multiple frontends are still required) and therefore a simple receiver structure is possible. Such techniques can be utilized in the downlink of a wireless communications system with V-BLAST or similar technique utilized in the uplink, creating a duplex system with a simple MS

transceiver structure. In the following, we utilize these three divisions and classify the systems accordingly.

#### **4.1 Receiver Processing Only**

This is the most common type of a MIMO antenna system and consists of processing the signals at the receiver only. Because the signal processing is restricted to the receiver, this type of system would be most useful in the uplink since no MIMO signal processing would be required at the MS. In uplink operation, a single data stream is demultiplexed into  $K$  substreams, and each substream is then modulated and passed into  $K$  transmitters. Each transmitter is itself an ordinary transmitter and the collection of the transmitters consists of a vector-valued transmitter, where components of each transmitted  $K$ -vector are symbols drawn from some constellation. The power radiated by each antenna is proportional to  $1/K$ , so that the total radiated power is constant and independent of  $K$ .

One of the most popular algorithms for performing the receiver processing is the V-BLAST algorithm [13]. Considering the uplink, the  $N$  receivers at the BS are individually conventional receivers, with each one receiving the signals radiated from all  $K$  transmit antennas and therefore considerable interference between the data streams will occur. The key to V-BLAST is how the interference between the streams is removed and the original data streams retrieved. This is achieved by utilizing both optimum combining and interference cancellation. Initially optimum combining (see Section 2.2) is performed for each of the data streams so that beam patterns are formed similar to that in Figure 2b. The single “best” (usually in terms of SNR) signal stream is then retrieved and output for detection. This signal is also cancelled from the remaining signals and therefore these signals are left with one less interferer. Optimum combining is then performed again and the “best” signal from the remaining

set again detected and also cancelled from the remaining signals. This process is continued until all the signals have been detected. The results for a V-BLAST system are shown in Figure 6 where it can be observed that good performance is achieved. The V-BLAST technique is a non-linear technique because of the ordering of the “best” signals for cancellation.

Another method, which has also been studied, is based on the Maximum likelihood detector (MLD) [12]. The MLD scheme is an optimum receiver that will perform better than V-BLAST. Its main disadvantage is that it has much higher complexity than V-BLAST. However, with small numbers of antennas (<3) and low order modulation, practical systems can be deployed. Some asymptotic bounds on the BER performance of MIMO MLD systems have been obtained in [12]. When perfect CSI is available and  $L$  is large, the BPSK MIMO MLD BER expression can be written as

$$P_e \approx \left( \frac{L}{4\gamma_b} \right)^L \binom{2L-1}{L-1}. \quad (2)$$

It should be noted that the results do not depend on  $K$ , the number of transmit streams, and the diversity order only depends on the number of receivers  $L$ . It is also interesting to compare (2) with (1), in its asymptotic form, where it can be observed that the results are very similar even though in the MIMO situation  $K$  streams are detected simultaneously.

Results of comparisons between V-BLAST and MLD are shown in Figure 6. When the number of receive and transmit antennas are approximately the same, then MLD has a large advantage over V-BLAST. The application of MIMO signal processing to OFDM systems has also been considered [18]

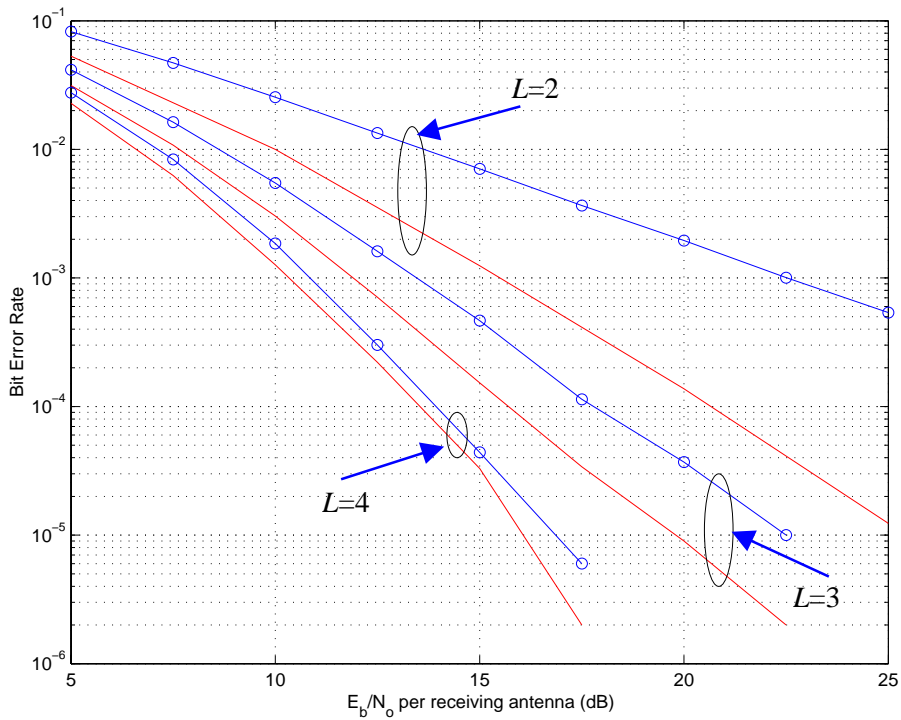
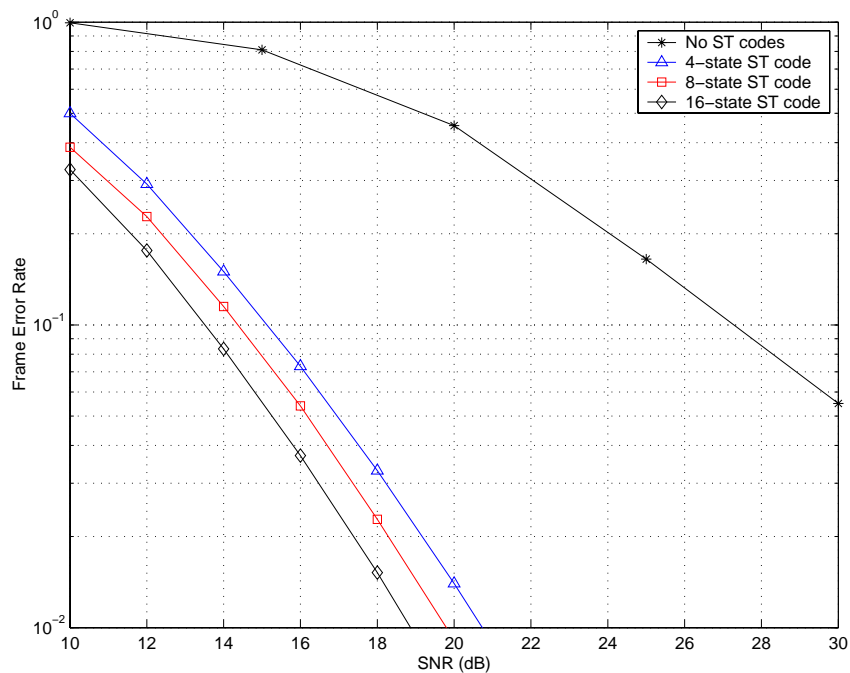

**Figure 6:** Performance comparison between MLD (solid lines) and BLAST (circled lines) with two transmit antennas ( $K=2$ ) and various numbers of receive antennas (in this case  $L$ ) with QPSK modulation.

Space-time coding is another approach that has received significant attention recently [6,16,19] in MIMO systems. This is because such a scheme can significantly improve the data rate and communication reliability over fading channels. In this scheme, all data are encoded across  $K$  antennas for transmit processing (refer to figure 1) while the receive processing uses a Maximum Likelihood decoder.

We classify space-time codes as a receiver based technique because most of the complexity is associated with the decoder at the receiver. Unlike the layered coding in the Layered space-time architecture, space-time coding was first realized by space-time trellis coding that truly and efficiently integrates the spatial diversity and temporal diversity provided by specific error control coding. Hence, a full diversity of order  $K \cdot L$  and substantial coding gain can be achieved. The disadvantage of space-time

codes is the high decoding complexity, which grows exponentially as a function of both the required capacity and the diversity order [16]. Thus, space time codes with low decoding complexity while retaining acceptable performance are quite desirable. The 2-transmit antenna diversity scheme discovered by Alamouti [6] is one solution. This approach has a very simple decoding process while retaining the full diversity gain  $2L$ . It was later generalized to an arbitrary number of transmit antennas as space time block coding. However, space-time block codes are not designed to provide significant coding gain. Hence, powerful outer code can be concatenated with space time block coding to achieve a required coding gain. It was shown that optimal trellis codes designed for the AWGN are also the best codes that achieve optimal error event probability for concatenation with space time block codes over Rayleigh fading channels. Results for some space-time codes are shown in Figure 7.



**Figure 7:** Performance of QPSK space-time (ST) codes over a flat Rayleigh fading channel with two transmit and one receive antennas and a frame size of 130 symbols.

Recently, there has been significant interest in applying space time codes to a variety of systems such CDMA based ones. Of particular interest is the application of space time codes to wideband OFDM systems where both the spatial and frequency diversity of OFDM systems can be taken advantage of to realize robust broadband and spectrally efficient wireless access [7].

#### **4.2 Transmitter Processing Only**

In this type of MIMO antenna system, the transmitter performs the MIMO signal processing only. Because the signal processing is restricted to the transmitter this type of system would be most useful in the downlink since no MIMO signal processing would be required at the MS and therefore the complexity of the MS would be limited (at the receiver multiple front ends are required but no MIMO processing is required). If we consider the downlink, then the receiver will consist of  $N$  antennas that are connected to  $N$  independent receivers that provide  $N$  data streams that are multiplexed and output.

Previous work on MIMO antenna systems with antenna processing at the transmitter and with a simple receive structure includes the transmit zero forcing scheme [17], transmit MMSE and the filter bank method. The transmit zero forcing scheme tries to pre-eliminate all the interference at the receiver. Some desired signal power is sacrificed during the pre-eliminating process and therefore, the received SNR may become very small. In contrast, the filter bank method provides a sub-optimal solution for the problem that maximizes the minimum signal-to-interference-plus-noise ratio (SINR) among all sub-channels. It must be also emphasized that none of these methods can provide receive diversity. Some comparisons between these

methods is provided in Figure 8. We have also included comparison with a receiver processing technique, V-BLAST.

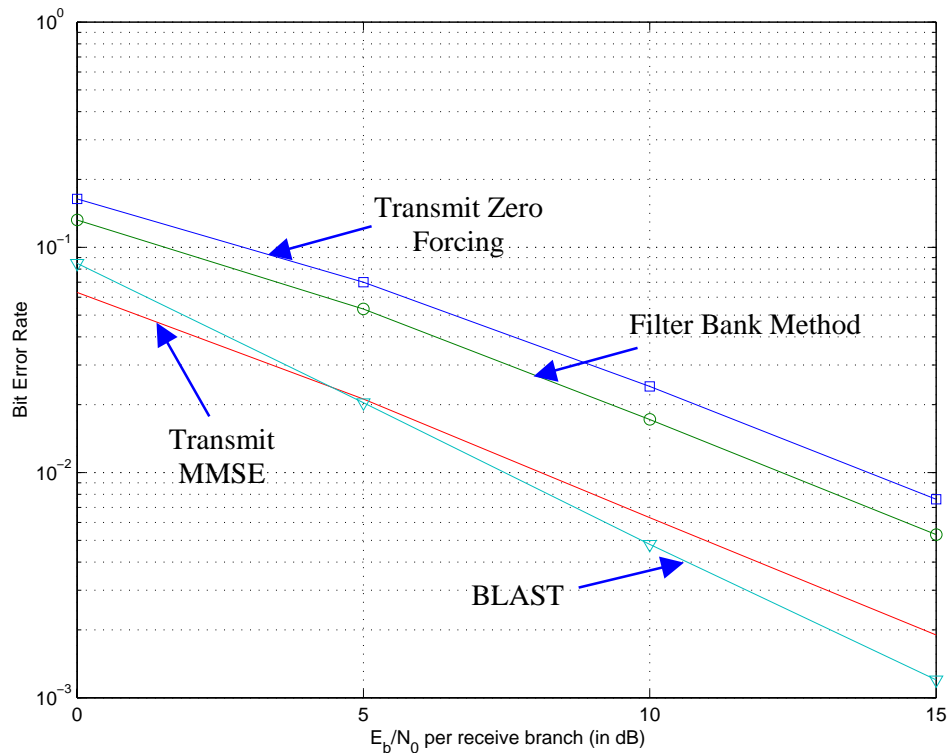

**Figure 8:** Performance Comparison of various MIMO transmitter based MIMO systems when  $M=N=4$ .

### 4.3 Processing at both the Receiver and Transmitter

In this case, MIMO antenna system processing is performed at both the receiver and transmitter and therefore should be able to provide better performance than the methods in Sections 4.1 and 4.2. Unfortunately, both the transmitter and receiver require MIMO signal processing and therefore a MS with reduced complexity may not be possible. Singular Value Decomposition (SVD) [14,15,18] can be used to diagonalize the MIMO channels to form independent channels and water filling can then be applied to maximize capacity.

## 5. Conclusions

In this paper, we have provided an overview of antenna systems for wireless broadband communications. We have approached the overview by considering the entire system with both an up and downlink system rather than concentrating on one of the links only. We have then used this framework to consider systems with only antenna systems at the BS, antenna systems at the MS and then antenna systems at both the BS and MS. Overall, we can conclude that MIMO antenna systems can provide tremendous capacity advantages without requiring extra bandwidth and power.

## References

- [1] J.H. Winters, "Optimum Combining in Digital Radio with Cochannel Interference", *IEEE J. Select. Areas Commun.*, Vol. 2, No. 4, pp. 528-539, July 1984.
- [2] RG Vaughan and J Bach Andersen, "Antenna Diversity in Mobile Communications," *IEEE Trans. Vehicular Technology*, Vol. 36, No. 4, pp. 149-172, Nov. 1987.
- [3] J.H. Winters, "Smart Antennas for Wireless Systems," *IEEE Personal Commun. Mag.*, Vol 5, No. 1, pp. 23-27, Feb. 1998.
- [4] A. Lozano, F. R. Farrokhi and R. A. Valenzuela, "Lifting the Limits on High-Speed Wireless Data Access Using Antenna Arrays," *IEEE Commun. Mag.*, Vol. 39, pp. 156-162, Sept. 2001
- [5] J. C.L. Ng, K. B. Letaief and R. D. Murch, "Antenna Diversity Combining and Finite-Tap decision Feedback Equalization for High-Speed Data Transmission," *IEEE J. Select. Areas Commun.*, Vol. 16, No. 8, pp. 1367-1375, Oct. 1998.
- [6] S. M. Alamouti, "A simple transmit diversity technique for wireless communications," *IEEE J. Select. Areas Commun.*, Vol. 16, No. 8, pp. 1451-1458, Oct. 1998.
- [7] Ye Li, J.C.chuang, and N.R. Sollenberger, "Transmitter diversity for OFDM systems and its impact on high-rate data wireless networks," *IEEE J. Sel. Areas Commun.*, Vol. 17, pp. 1233-43, July 1999.
- [8] L-U Choi, K. B. Letaief, and R. D. Murch "MISO CDMA Transmission with Simplified Receiver for Wireless Communication Handsets," *IEEE Trans. Commun.*, Vol. 49, pp. 888-898, May 2001.
- [9] Ying-Chang Liang, and Francois Chin, "Two Suboptimal Algorithms for Downlink Beamforming in FDD DS-CDMA Mobile Radio," *IEEE J. Select. Commun.*, July 2001
- [10] Samuel CK Ko and R. D. Murch, "Compact Integrated Diversity Antenna for Wireless Communications," *IEEE Trans. Antennas and Propagation*, Vol. 49, No. 6, pp. 954-960, June 2001.
- [11] PB Wong and DC Cox, "Low Complexity Diversity Combining Algorithms and Circuit Architectures for Co-Channel Interference Cancellation and Frequency-Selective Fading Mitigation," *IEEE Trans. Commun.*, Vol. 44, No 9, pp. 1107-1116, Sept. 1996.
- [12] Zhu Xu and RD Murch, "Performance Analysis of Maximum Likelihood Detection in a MIMO Antenna System", *To Appear in IEEE Transaction on Communications*.
- [13] G. D. Golden, C. J. Foschini, R. A. Valenzuela, P. W. Wolniansky, "Detection algorithm and initial laboratory results using V-BLAST space-time communication architecture," *IEE Electronics Letters*, Vol.35, No.1, pp. 14-16, 7 Jan. 1999.
- [14] J Bach Andersen, "Array gain and capacity for known random channels with multiple element arrays at both ends," *IEEE J. Select. Areas Commun.*, Vol. 18, Issue 11, pp. 2172-2178, Nov. 2000.
- [15] W. K. Wong, R. D. Murch, and K. B. Letaief, "Optimizing Time and Space MIMO Antenna System for Frequency Selective Fading Channels," *IEEE J. Select. Areas Commun.*, Vol. 19, No. 7, pp. 1395-1407, July 2001.

- [16] A. F. Naguib, V. Tarokh, N. Seshadri, and A. R. Calderbank, "A space-time coding modem for high data rate wireless communications," *IEEE J. Select. Areas Commun.*, Vol. 16, No. 8, pp. 1459-1478, Oct. 1998.
- [17] H. Sampath, and A. J. Paulraj, "Joint transmit and receive optimization for high data rate wireless communications using multiple antennas," Thirty-third Asilomar Conference on Signals, Systems, and Computers, 1999, vol. 1, pp.215-219.
- [18] K.K. Wong, RS Cheng, K.B. Letaief and R.D. Murch, "Adaptive Antennas in the Mobile and Basestations in an OFDM/TDMA System," *IEEE Trans. Commun.*, Vol. 49, pp. 1-8, Jan. 2001.
- [19] Gong Yi and K. B. Letaief, "Performance evaluation and analysis of space-time coding in unequalized multipath fading links," *IEEE Trans. Commun.*, Vol. 48, No. 11, Nov. 2000.

## Biography of Ross Murch



Dr Ross MURCH is an Associate Professor in the Department of Electrical and Electronic Engineering at the Hong Kong University of Science and Technology. His current research interests include smart antenna systems, compact antenna design and propagation characterization for wireless communications. He has several US patents related to wireless communication, over 100 published papers and acts as a consultant for industry on occasions. In addition he is an editor for the IEEE Transactions on Wireless Communications and acts as a reviewer for several journals. He is the Chair of the Advanced Wireless Communications Systems Symposium at ICC 2002 and is also the founding Director of the Center for Wireless Information Technology at Hong Kong University of Science and Technology which was begun in August 1997. From August-December 1998 he was on sabbatical leave at Allgon Mobile Communications (manufactured 1 million antennas per week), Sweden and AT&T Research Labs, NJ, USA.

Dr Ross Murch received his bachelors degree in Electrical and Electronic Engineering from the University of Canterbury, New Zealand where he graduated in 1986 with first class honors and was ranked first in his class. During his bachelors degree he was the recipient of several academic prizes including the John Blackett prize for engineering and also the Austral Standard Cables prize. In 1990 he completed his PhD, also in Electrical and Electronic Engineering at the University of Canterbury. During his PhD he was awarded a RGC and also a New Zealand Telecom scholarship. From 1990-92 he was a post doctorate fellow at the Department of Mathematics and Computer Science at Dundee University, Scotland. From 1992-1998 he was an Assistant Professor in the Department of Electrical and Electronic Engineering at the Hong Kong University of Science and Technology and since 1998 he has been an Associate Professor there. He is a senior member of IEEE, a Chartered Engineer and a member of IEE. In 1993 and 1996 he won an URSI young scientist and engineering teaching excellence appreciation awards respectively.

## Biography of Khaled Ben Letaief



Khaled Ben Letaief received the BS degree *with distinction* in Electrical Engineering from Purdue University at West Lafayette, Indiana, USA, in December 1984. He received the MS and Ph.D. Degrees in Electrical Engineering from Purdue University, in August 1986, and May 1990, respectively. From January 1985 and as a Graduate Instructor in the School of Electrical Engineering at Purdue University, he has taught courses in

From 1990 to September 1993, he was a faculty member in the Department of Electrical and Electronic Engineering at the University of Melbourne, Australia where he was also a member of the Center for Sensor Signal and Information Systems. Since September 1993, he has been with the Department of Electrical & Electronic Engineering at the Hong Kong University of Science & Technology (HKUST) where he is now a Professor. His current research interests include wireless and mobile communications, OFDM, Space-time processing for wireless systems, Multiuser detection, Wireless multimedia communications, and CDMA systems.

In January 2002, Dr. Letaief has been appointed the founding Editor-in-Chief of the *IEEE TRANSACTIONS ON WIRELESS COMMUNICATIONS*. He has served on the editorial board of other journals including the *IEEE Transactions on Communications*, *IEEE Communications Magazine*, *Wireless Personal Communications*, and *IEEE Journal on Selected Areas in Communications – Wireless Series* (as Editor-in-Chief). He served as the Technical Program Chair of the 1998 *IEEE Globecom Mini-Conference on Communications Theory*, held in Sydney, Australia. He is also the Co-Chair of the 2001 *IEEE ICC Communications Theory Symposium*, held in Helsinki, Finland. He is currently serving as Vice-Chair of the IEEE Communications Society Technical Committee on Personal Communications. He is also currently the Vice chair of Meeting and Conference Committee of the IEEE COMSOC Asia Pacific Board.

In addition to his active research activities, Professor Letaief has also been a dedicated teacher committed to excellence in teaching and scholarship. He received the *Mangoon Teaching Award* from Purdue University in 1990; the Teaching Excellence Appreciation Award by the School of Engineering at HKUST in Spring 1995, Fall 1996, Fall 1997, and Spring 1999; and the Michael G. Gale Medal for Distinguished Teaching (*Highest university-wide teaching award* and only one recipient/year is honored for his/her contributions).